

Icom 706 MKIIG Zeroizer

by

KA6BFB

I am a fan of the 706, and I own a few of them. I like to use them for everything. I have used it for transmitter hunting, but I found I needed a little more granularity than was available from the LCD bar graph S meter. I found the analog S meter voltage in the radio that is used by the A/D converter in the microcontroller to drive the LCD bar graph. Unfortunately, the analog voltage is around 4 volts with no signal, and around 1 volt with maximum signal. This voltage is difficult to use in this state, and is the genesis of the Zeroizer.

The Zeroizer transforms the voltage in the 706 to a voltage at 0 Volts with no signal and about 3.5 volts with maximum signal. The signal is also a low impedance output that is suitable for bringing outside the radio through the accessory or microphone jacks. Among other things, I use this voltage to drive a large external analog panel meter and audible S meters that are described in other projects on this website.

The tap point for the internal signal is shown below in Figure 1. The schematic node and the actual resistor location are shown for easy identification.

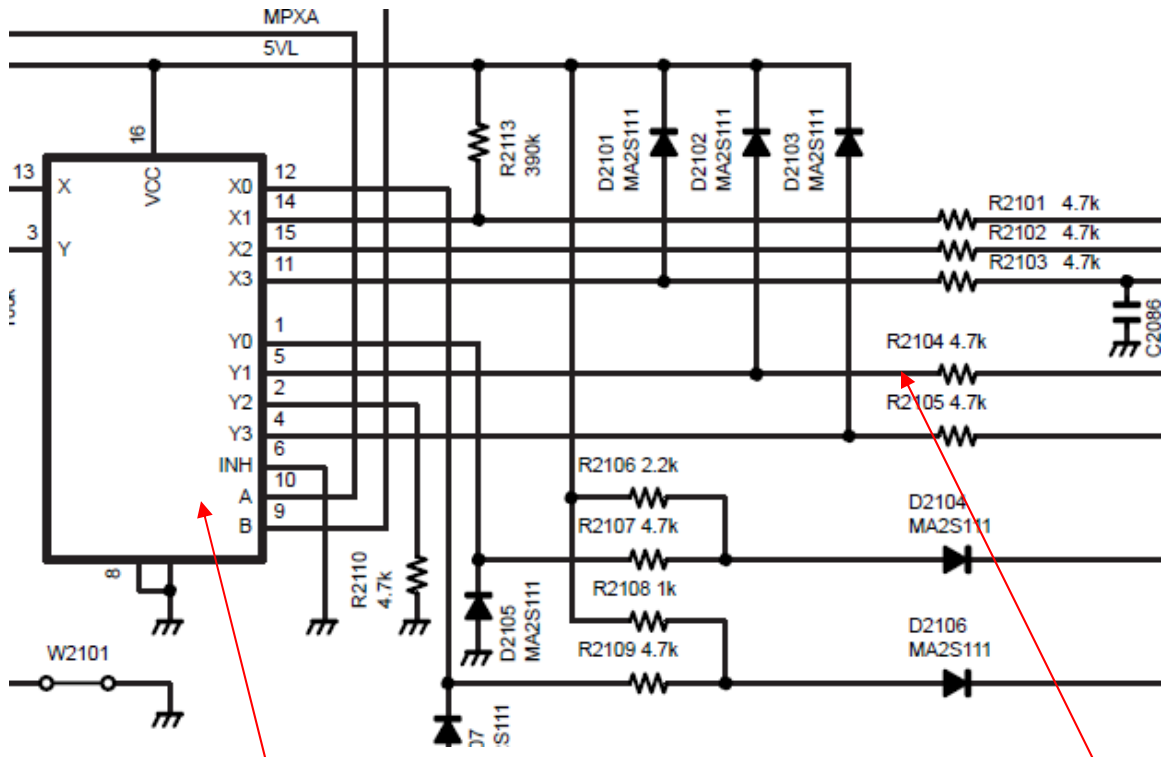

IC210

Analog Signal Voltage

R2104

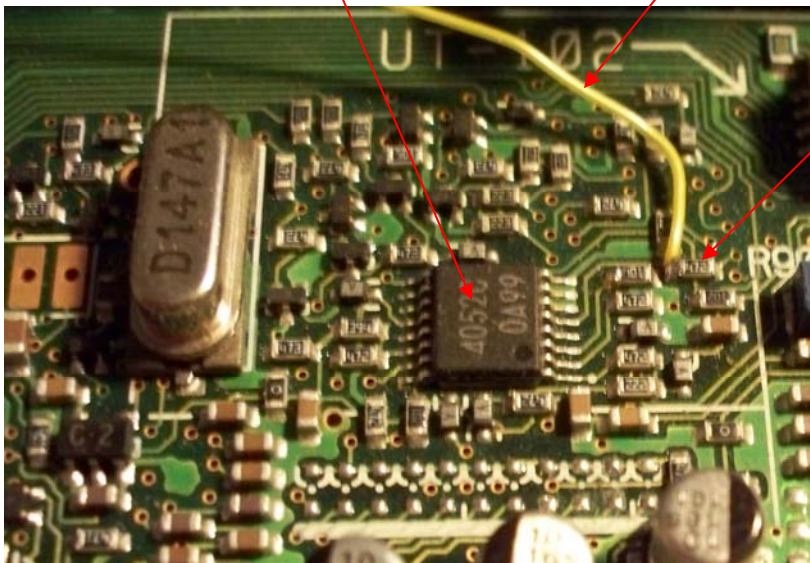

Figure 1. Locations of internal S meter signals

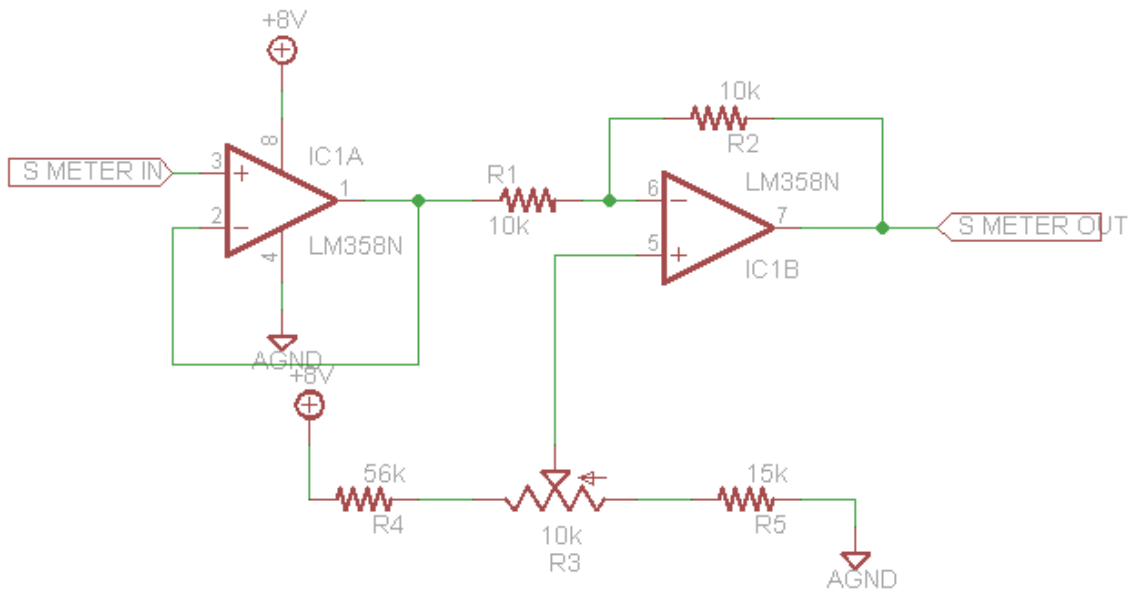

Figure 2. Zeroizer schematic

Figure 2 shows the Zeroizer schematic. R3 is adjusted with no received signal while measuring the output. Starting with a positive value on the output, adjust the pot until the output voltage stops changing, very near 0 volts. Verify proper operation with signals present. The output should rise above 0 volts with the slightest signal present, and reach a maximum of about 3.5 volts with maximum signal strength. Make sure to use a .1uF bypass capacitor between pin 4 and 8.

Figure 3 shows the completed Zeroizer constructed on a little board. The tap point for the regulated 8V from the radio is shown in Figure 4. The output of the Zeroizer is fed to the accessory jack and pin 2 of the Mic Jack which is usually used for Up/Down control which I never use so I disabled that function.



Figure 3. Zeroizer circuit installed in 706

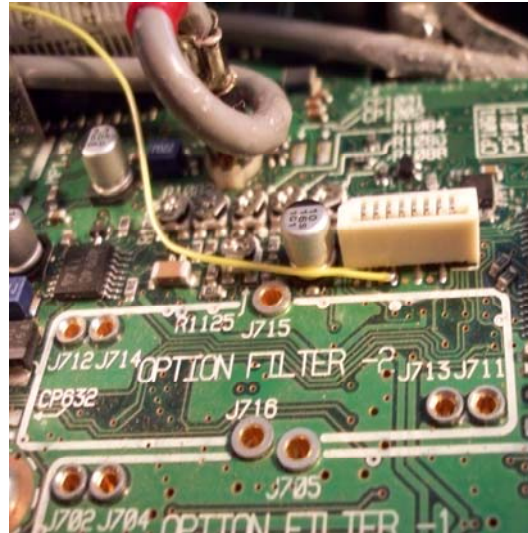

Figure 4. Tap point for Internal 8V

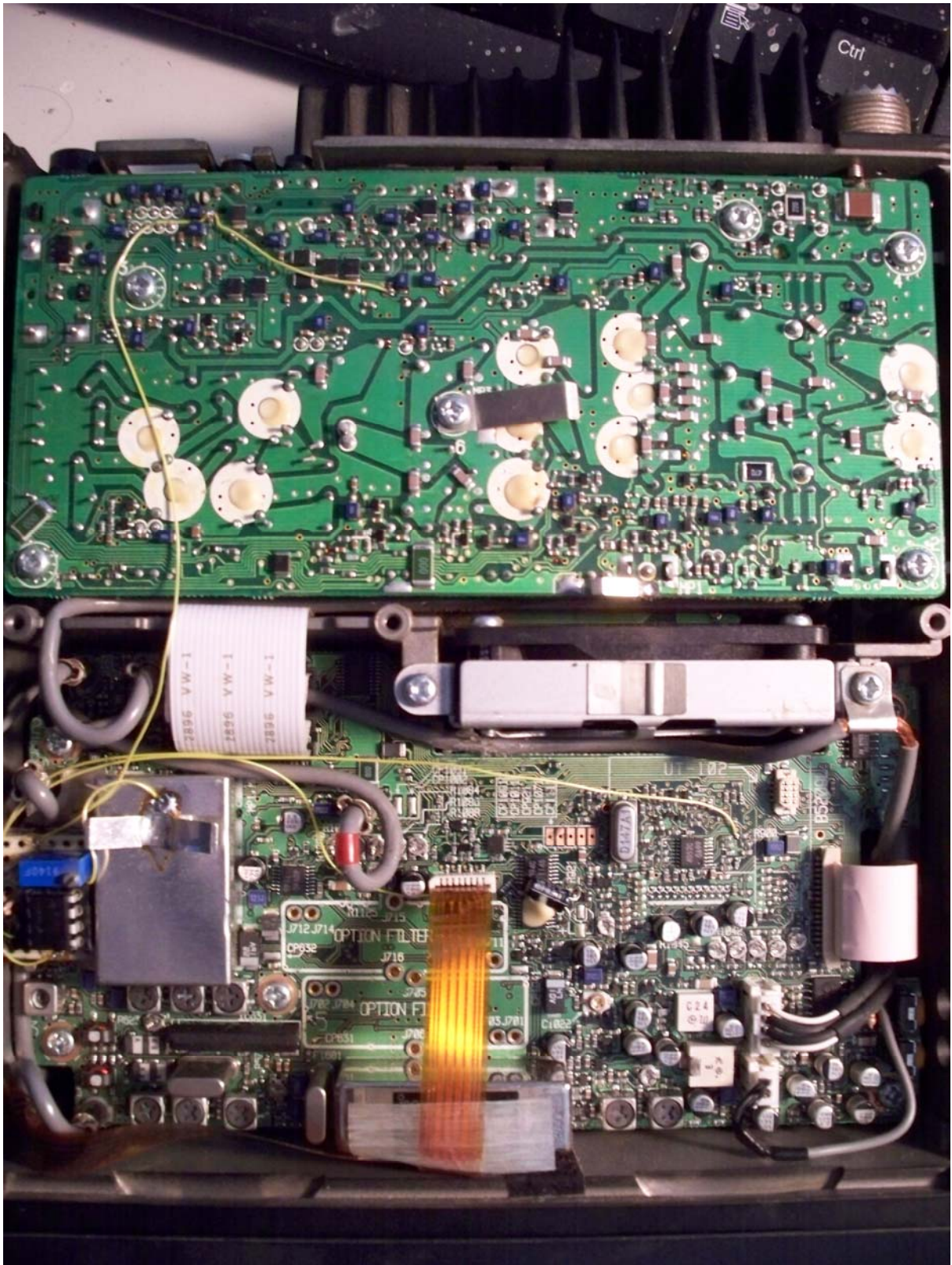

Figure 5. Final configuration of Zeroizer circuit